

PL EN

DOMEK NARZĘDZIOWY 308X283X192 CM Z FUNDAMENTEM

Instrukcja montażu i obsługi

TOOL SHED 308X283X192 CM WITH FOUNDATION

Instruction Manual

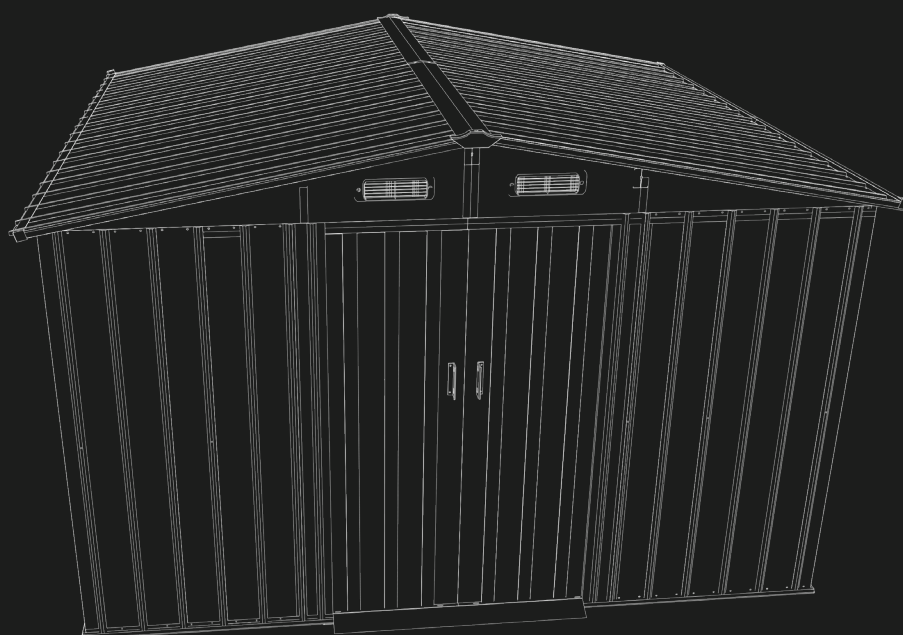

308X283X192 CM



DOMEK NARZĘDZIOWY Z FUNDAMENTEM





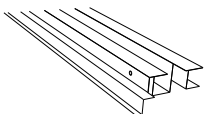
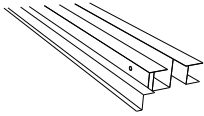
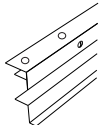
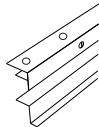
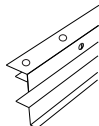
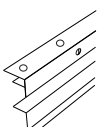

Producent:

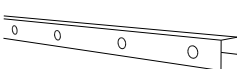
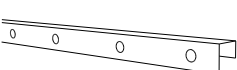
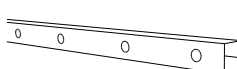
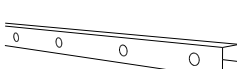
Mirpol sp. z o.o.
ul. Ciasna 3, 35-232 Rzeszów
biuro@mirpol.rzeszow.pl
www.mirpol.rzeszow.pl
Made in China

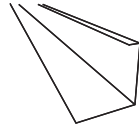
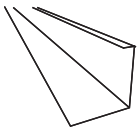
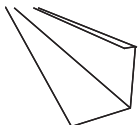
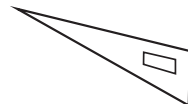
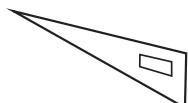
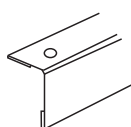



mirpol

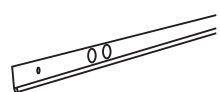



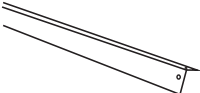
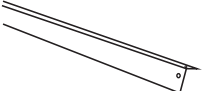
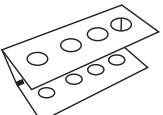
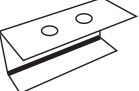
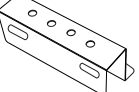
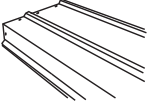

LISTA CZĘŚCI / PARTS LIST

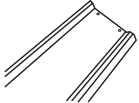
NUMER NO.	RYSUNEK DRAWING	ILOŚĆ QTY
1L		1
1R		1
2F		2
2B		2
3L		1
3R		1
4L		1
4R		1
5F		2
5B		2
6L		1
6R		1

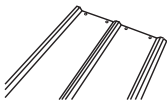

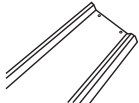
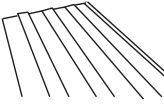

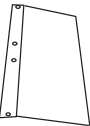

NUMER NO.	RYSUNEK DRAWING	ILOŚĆ QTY
7		4
8B		2
8F		2
9		2
10		2
15		1
16		3
16A		3
16C		3
16L		3
16R		3
17		4

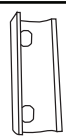
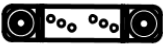

LISTA CZĘŚCI / PARTS LIST

NUMER NO.	RYSUNEK DRAWING	ILOŚĆ QTY
18R		4
18		2
18L		2
19L		1
19R		1
20		1
21		3
22		5
Q2Z		4
Q3		12
Q2		10
D1		2

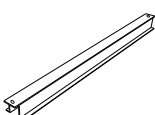
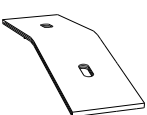
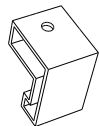
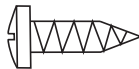
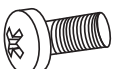
NUMER NO.	RYSUNEK DRAWING	ILOŚĆ QTY
D2		4
D3		8
D4		2
M1		1
M2		1
23		1
K1		1
K2		1

LISTA CZĘŚCI / PARTS LIST

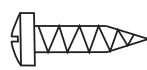
NUMER NO.	RYSUNEK DRAWING	ILOŚĆ QTY
A		2
C		4
B		4
D		2
G		4
30		6
29		29
H		1
J		2
S1		462
S2		185
S3		411

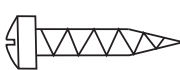
NUMER NO.	RYSUNEK DRAWING	ILOŚĆ QTY
S4		185
S5		8
S7		100
S8		4

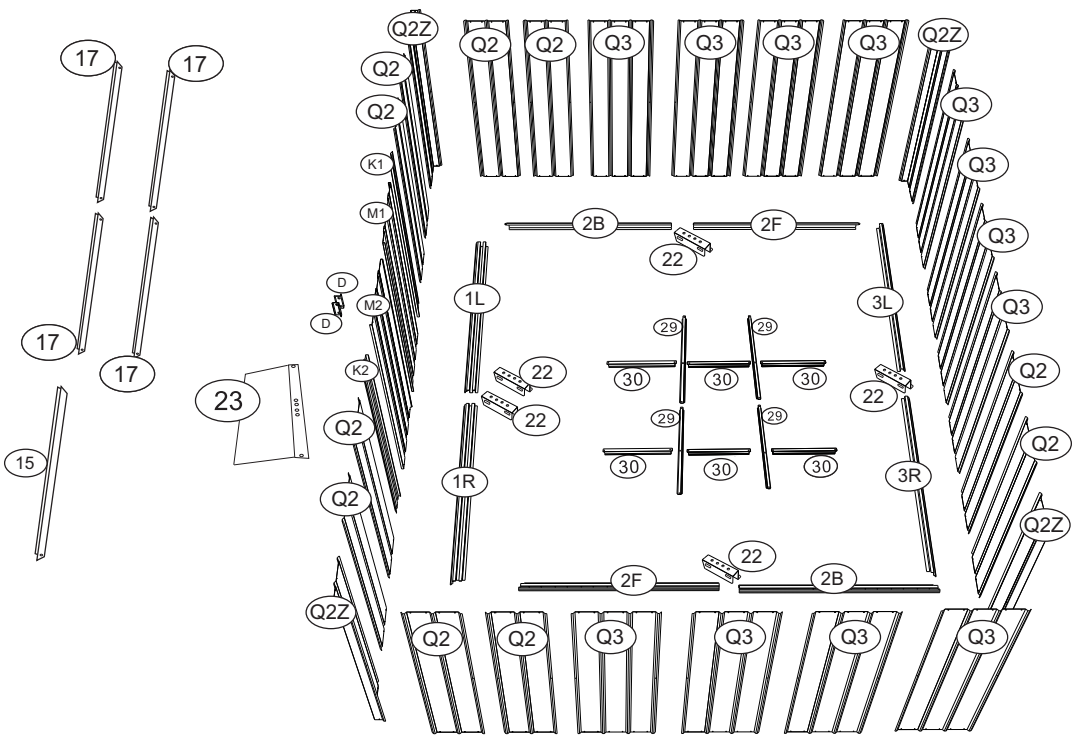
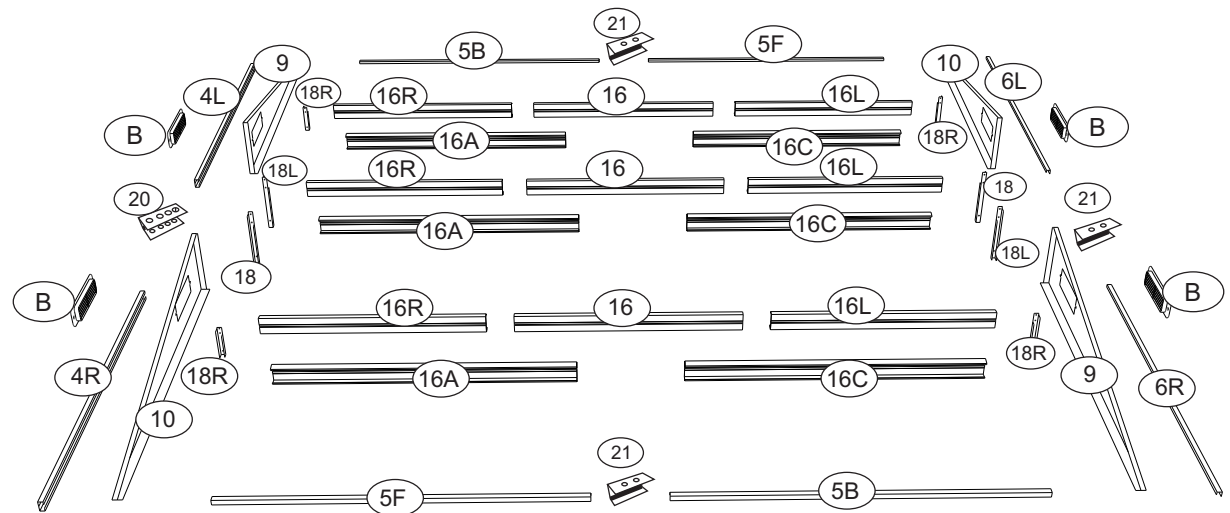
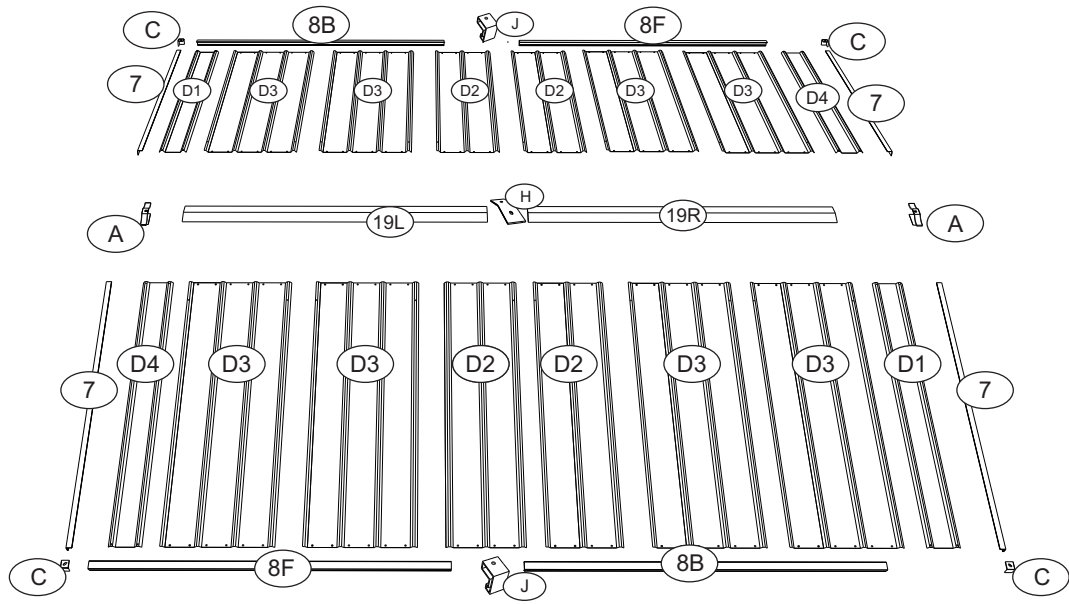

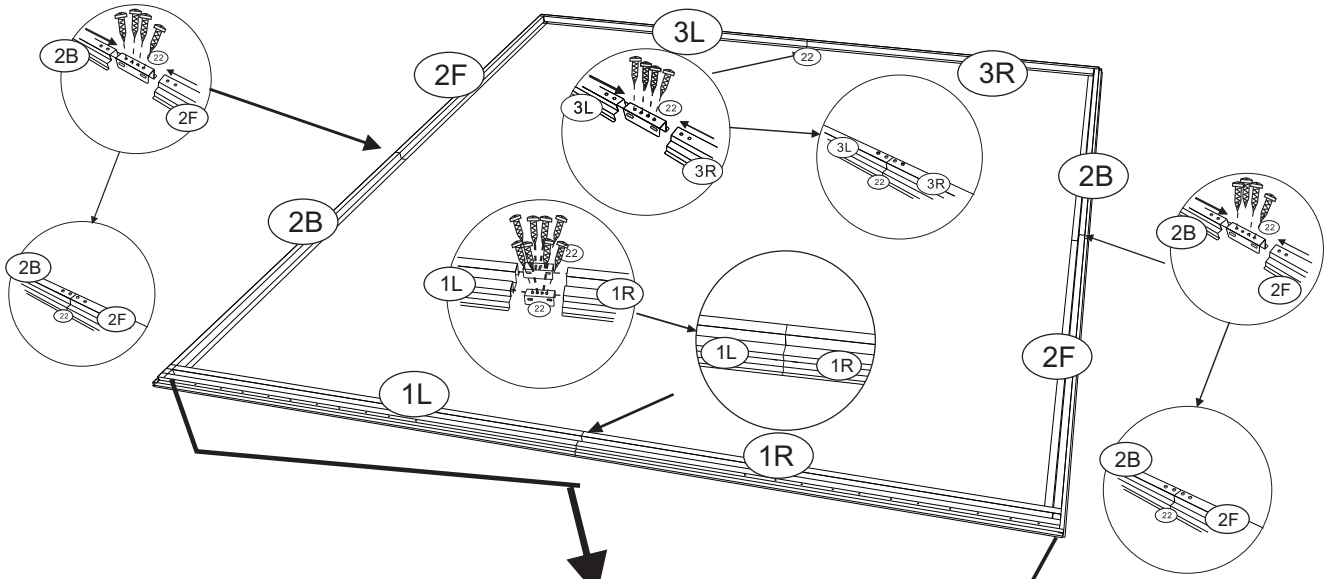



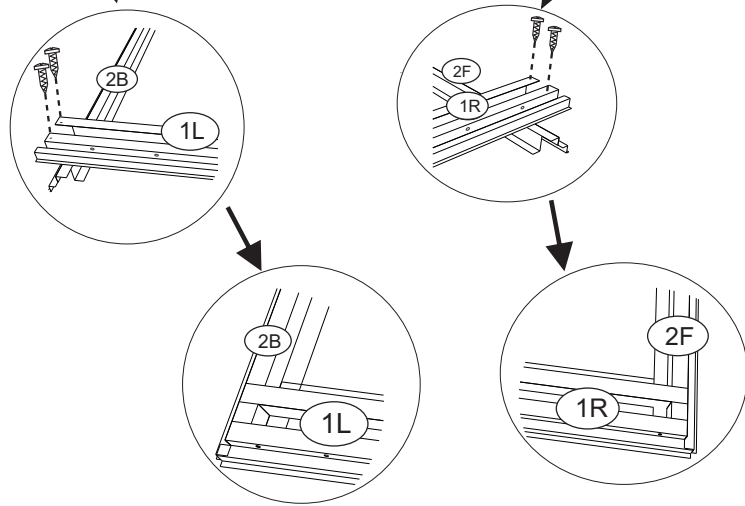

CZĘŚĆ PART	NR NO.	ILOŚĆ QTY
	1L	1
	1R	1
	2B	2
	2F	2
	3L	1
	3R	1
	S1	26
	22	5

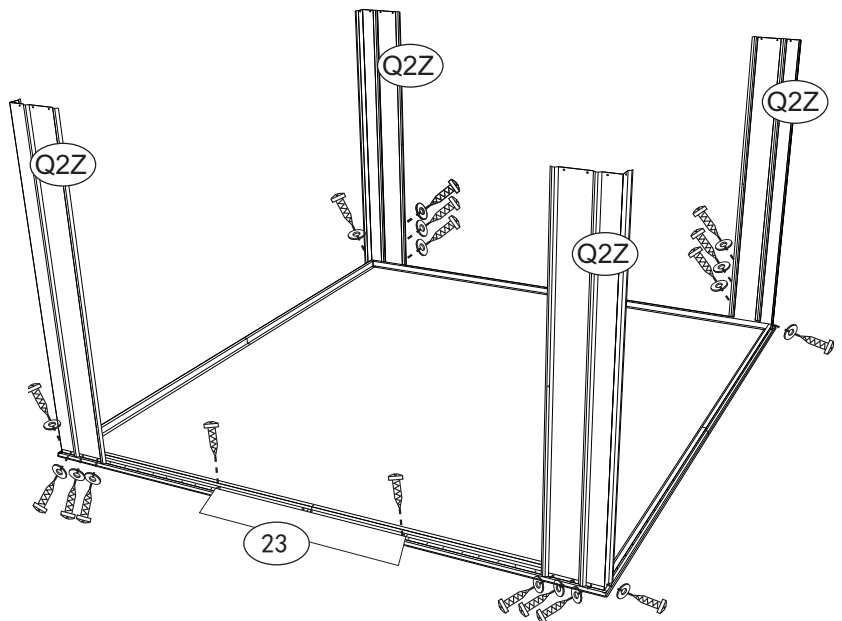

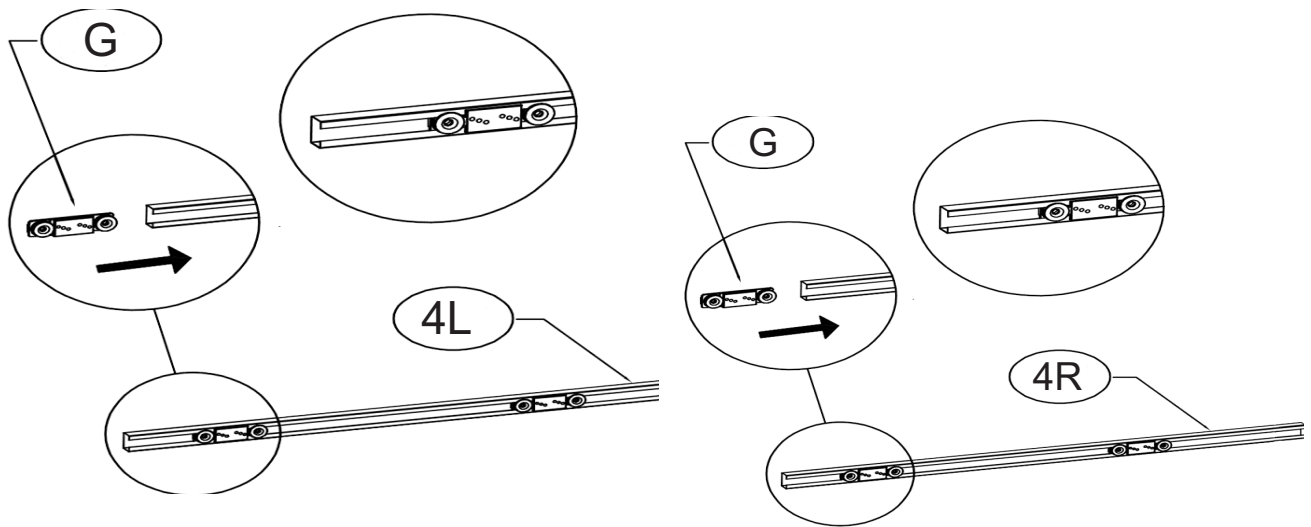







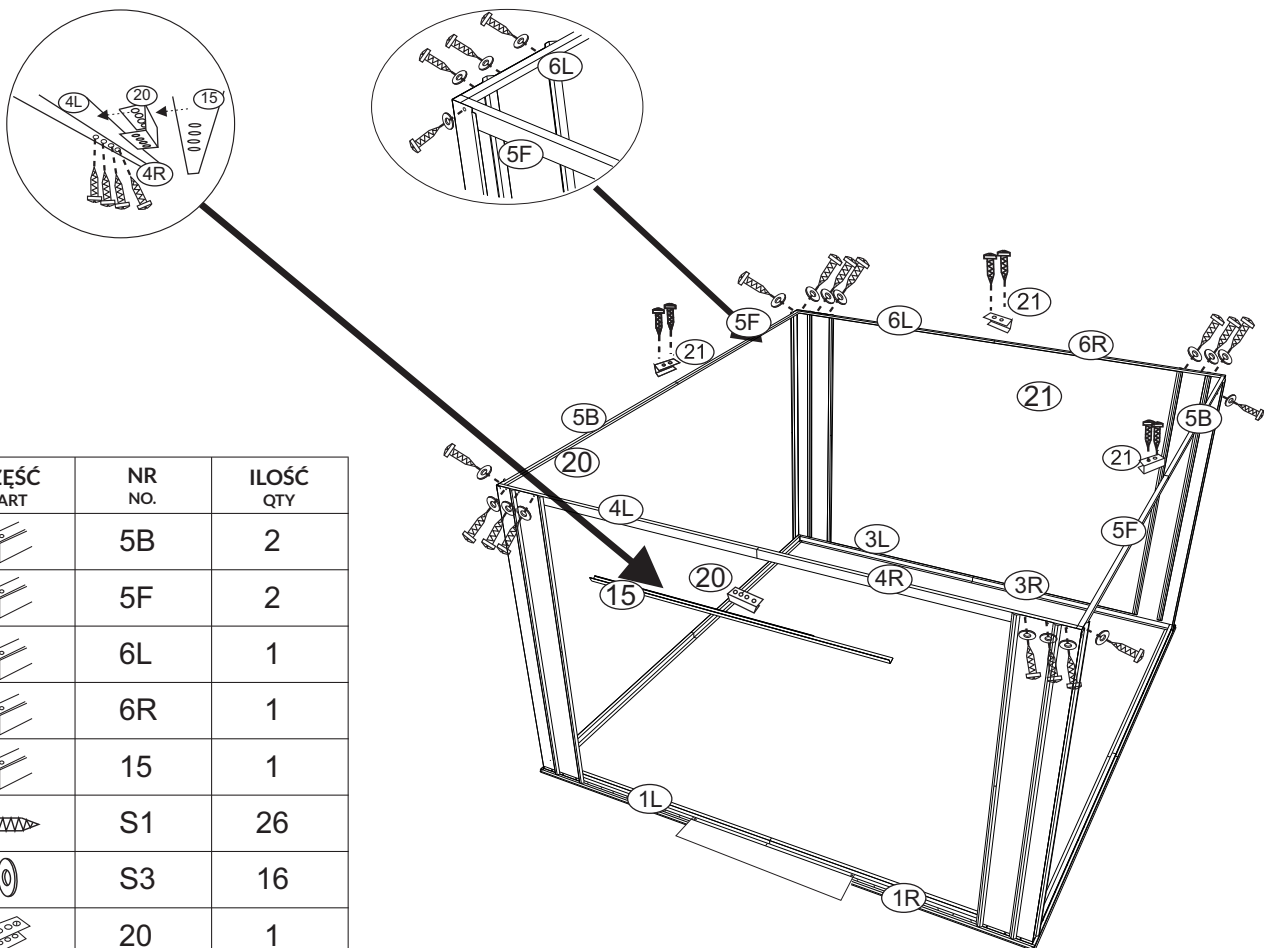

CZĘŚĆ PART	NR NO.	ILOŚĆ QTY
	Q2Z	4
	S1	18
	S3	16
	23	1









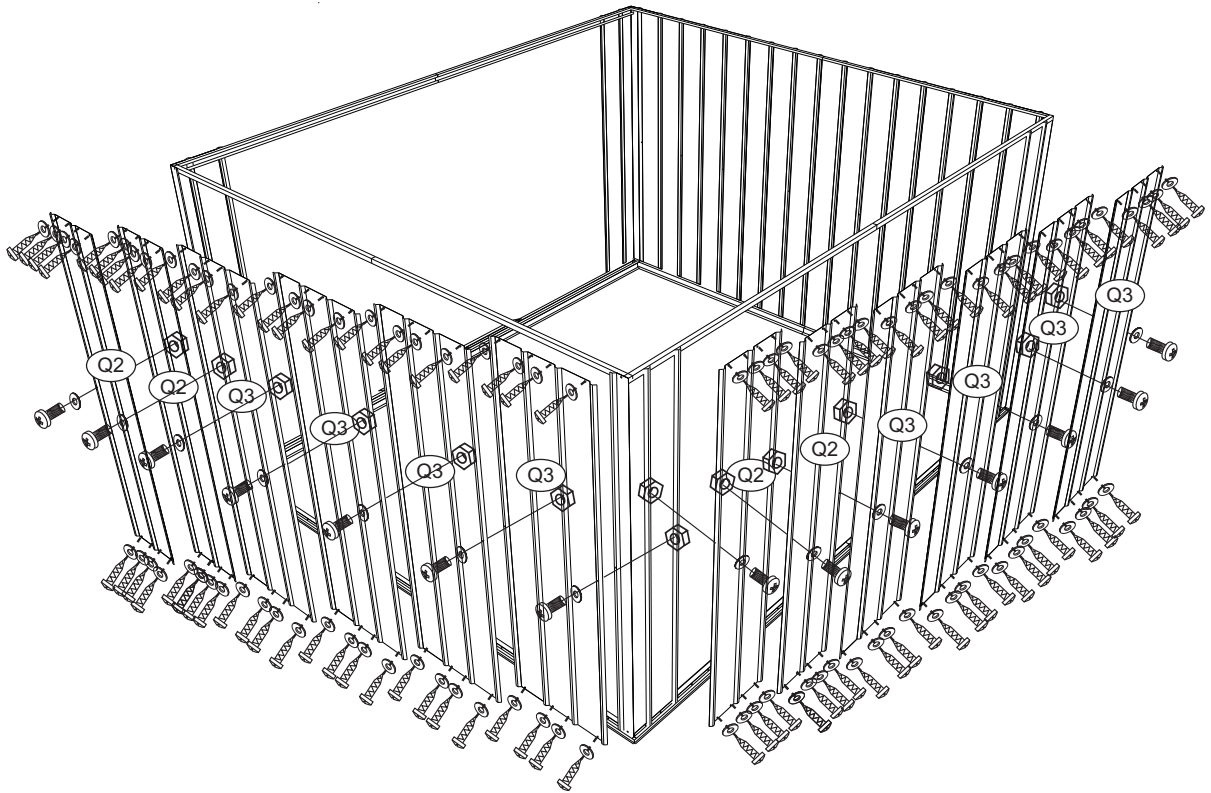
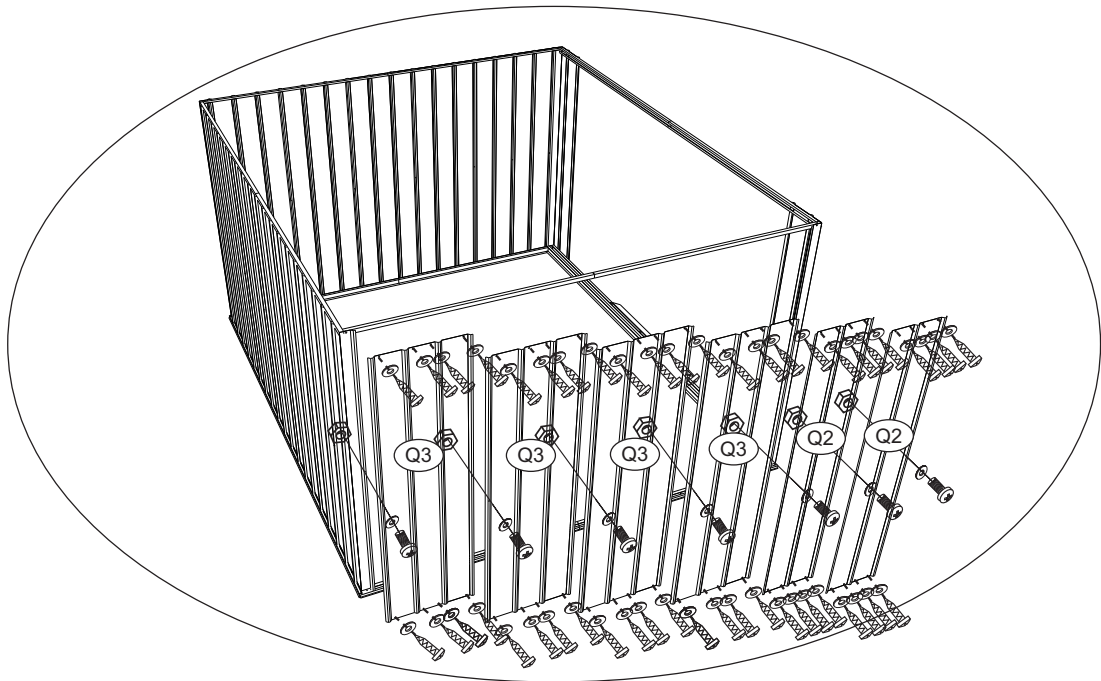

CZĘŚĆ PART	NR NO.	ILOŚĆ QTY
	4L	1
	4R	1
	G	4







CZĘŚĆ PART	NR NO.	ILOŚĆ QTY
	5B	2
	5F	2
	6L	1
	6R	1
	15	1
	S1	26
	S3	16
	20	1
	21	3

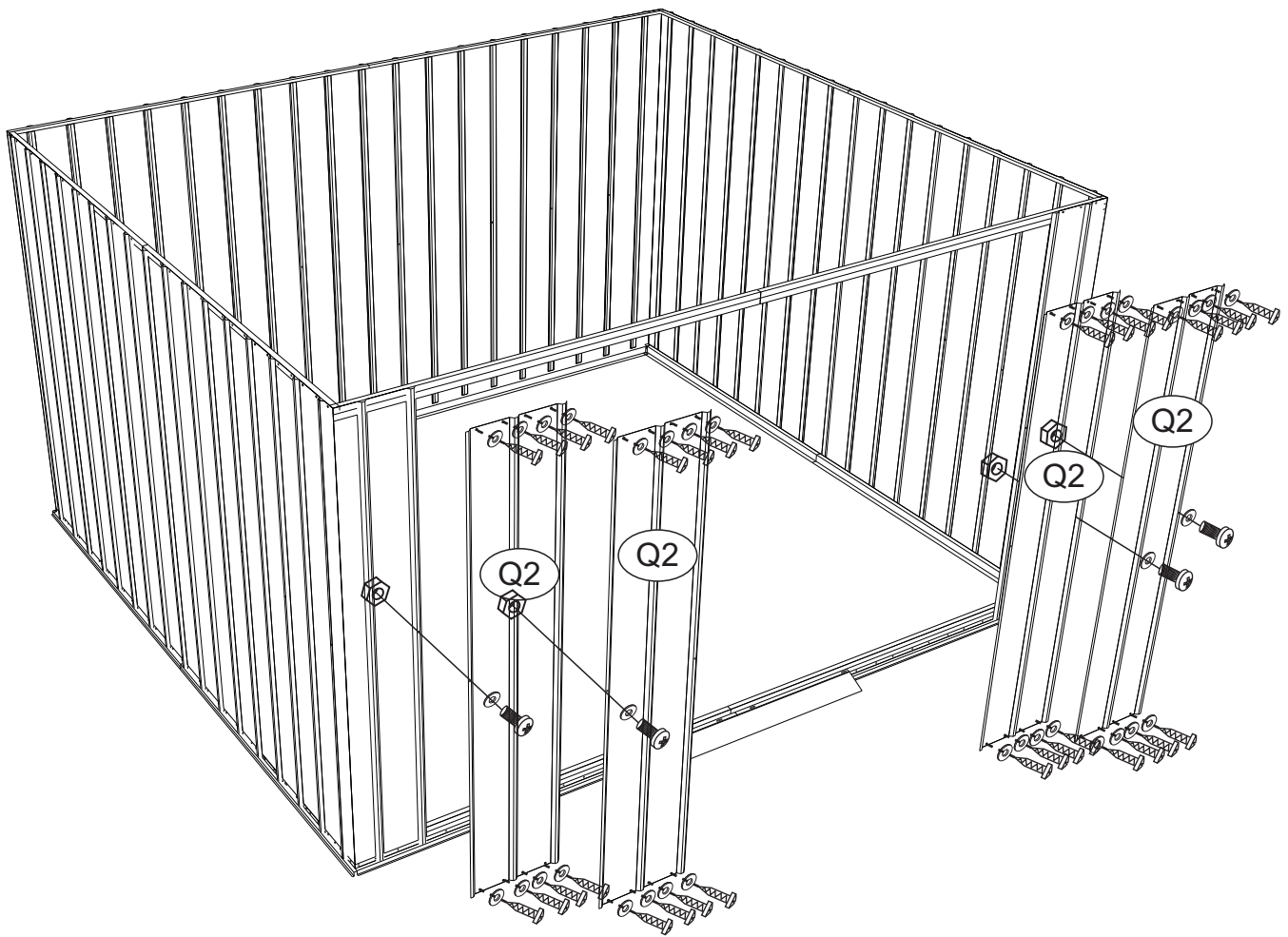





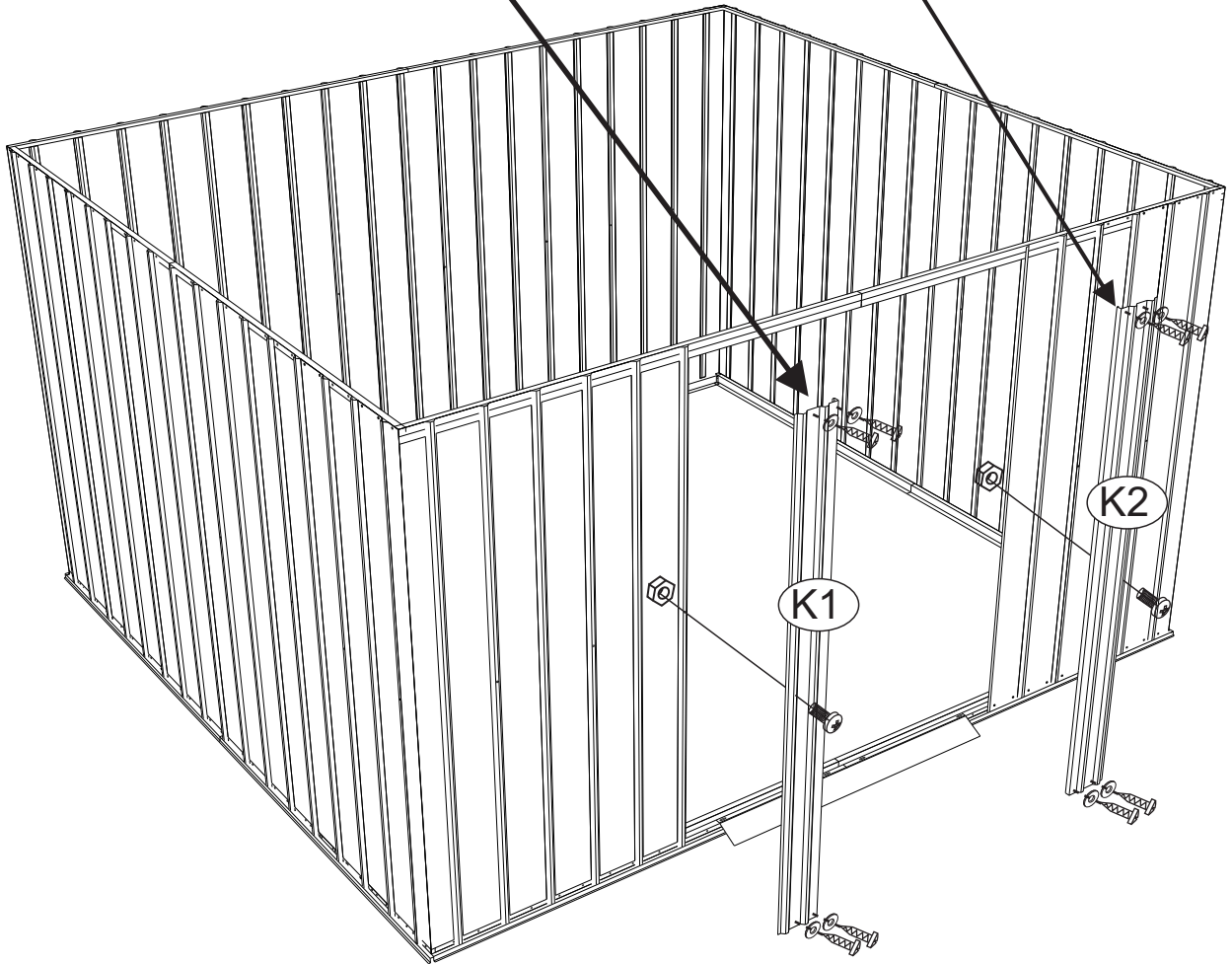
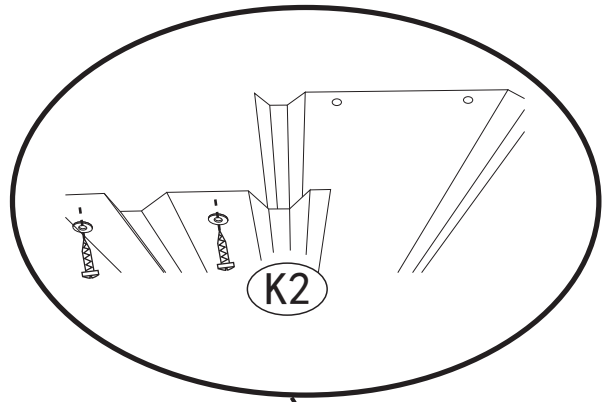
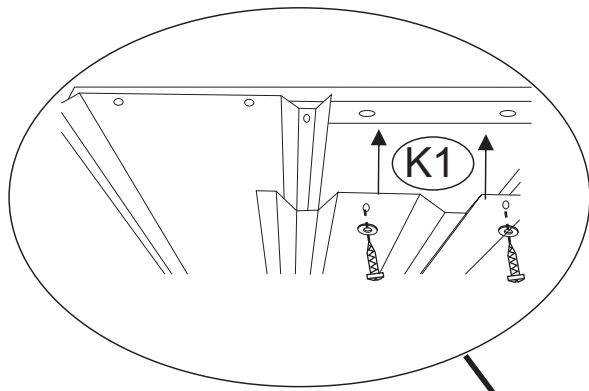

CZEŚĆ PART	NR NO.	ILOŚĆ QTY
	Q2	6
	Q3	12
	S1	144
	S2	21
	S3	165
	S4	21







CZĘŚĆ PART	NR NO.	ILOŚĆ QTY
	Q2	4
	S1	32
	S2	4
	S3	36
	S4	4

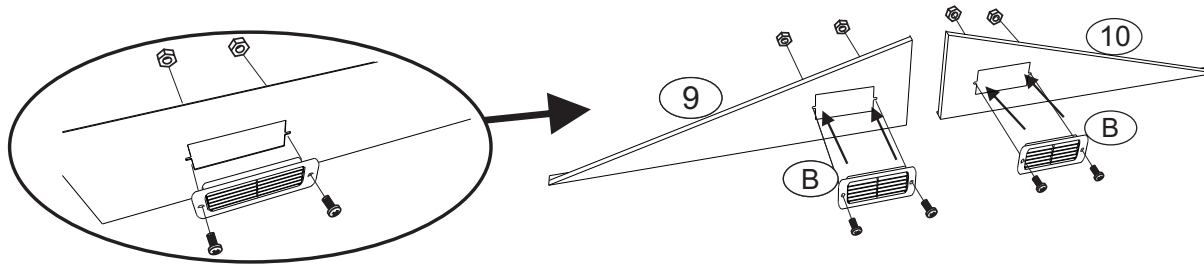

CZĘŚĆ PART	NR NO.	ILOŚĆ QTY
	K1	1
	K2	1
	S1	8
	S2	2
	S3	8
	S4	2





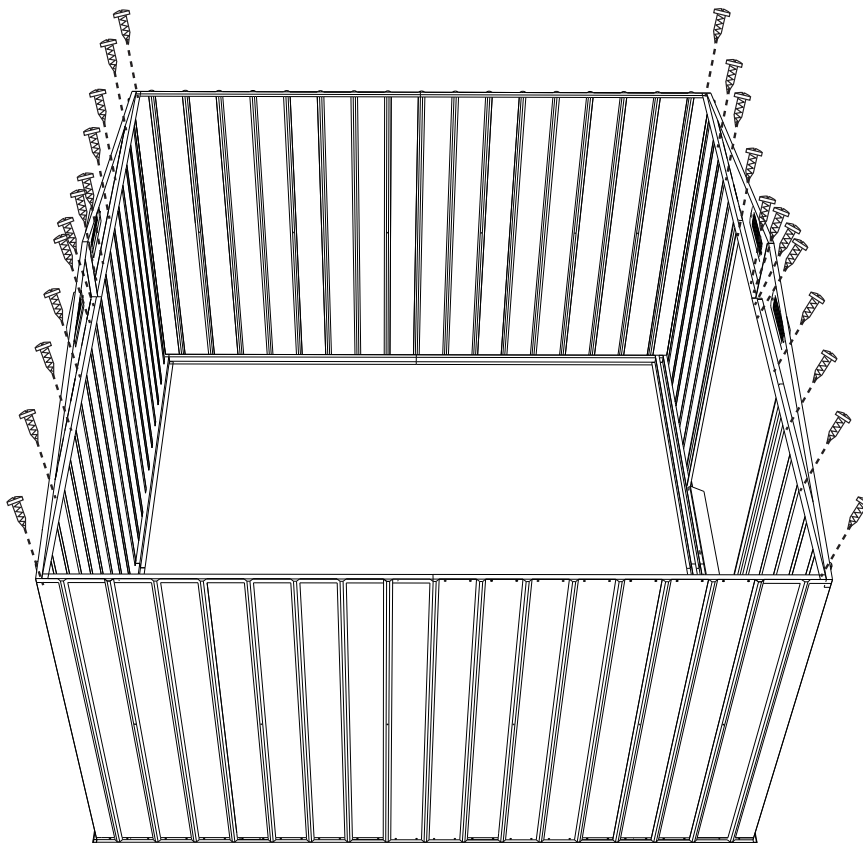
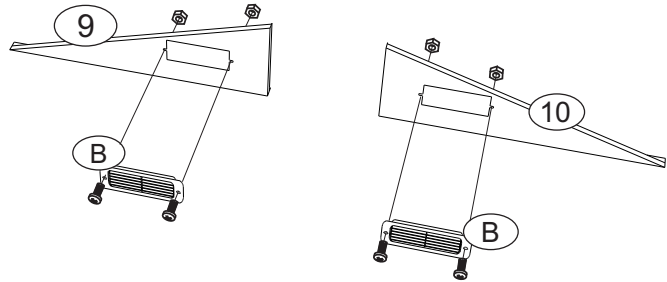

CZĘŚĆ PART	NR NO.	IŁOŚĆ QTY
	9	2
	10	2
	B	4
	S2	8
	S4	8

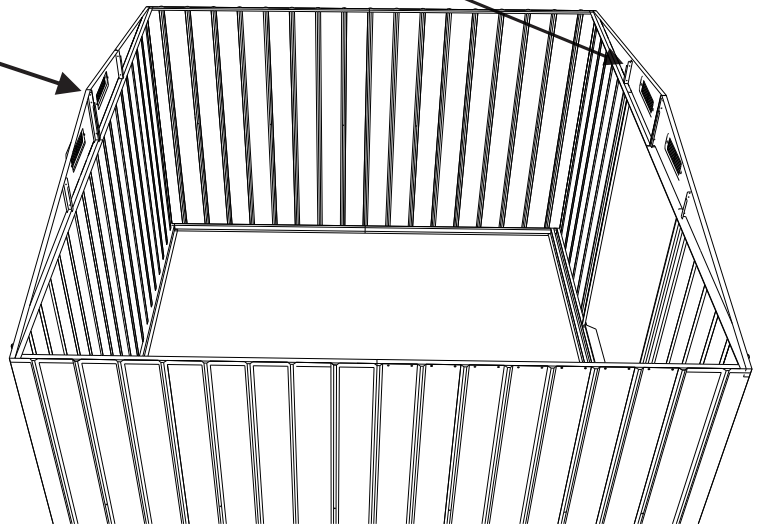
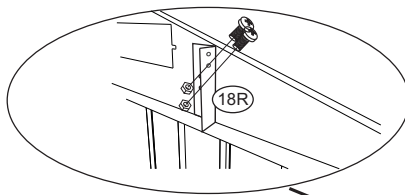
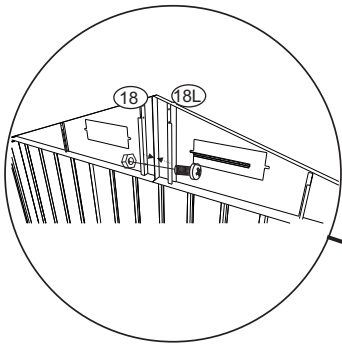





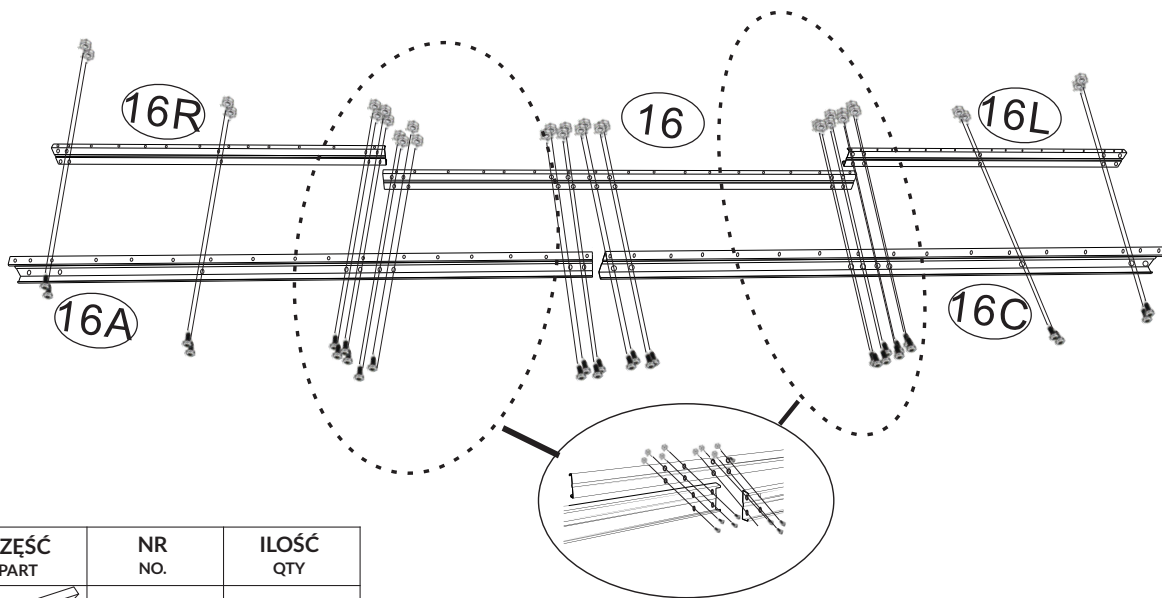

CZĘŚĆ PART	NR NO.	IŁOŚĆ QTY
	S1	24

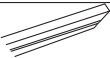

CZĘŚĆ PART	NR NO.	ILOŚĆ QTY
	18	2
	18L	2
	18R	4
	S2	10
	S4	10

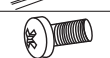

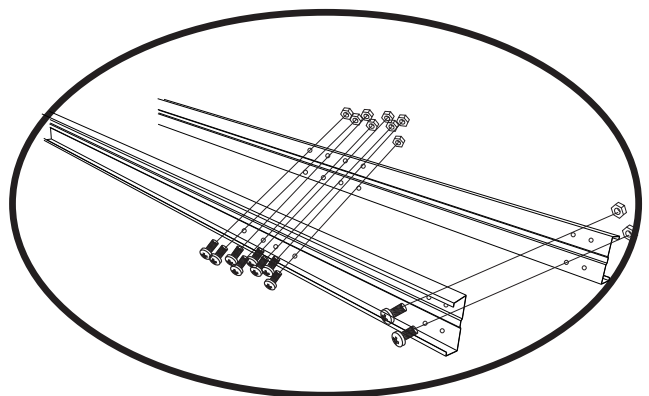

CZĘŚĆ PART	NR NO.	ILOŚĆ QTY
	16	3
	16A	3
	16C	3
	16L	3
	16R	3
	S2	108
	S4	108

X3

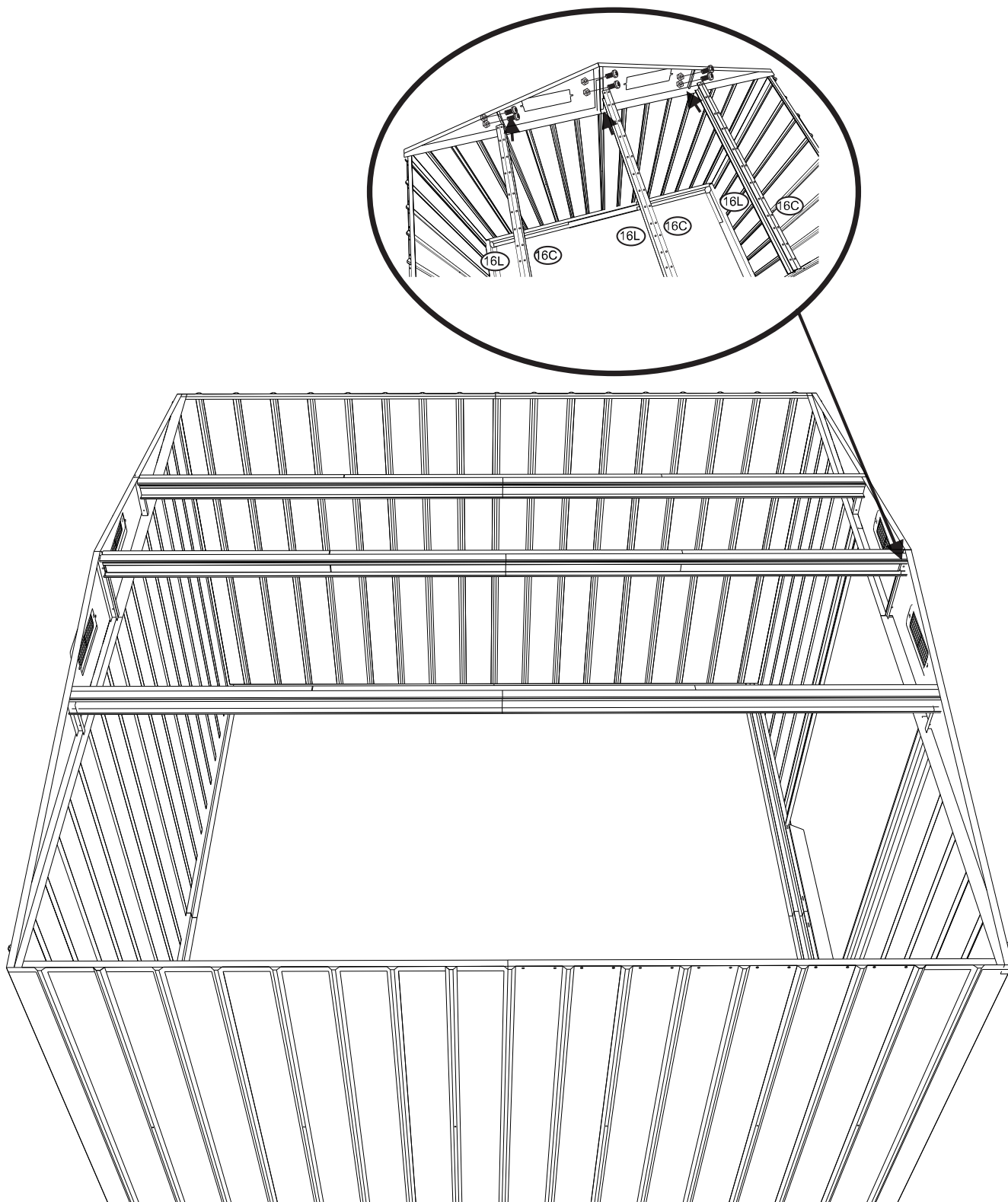



CZĘŚĆ PART	NR NO.	ILOŚĆ QTY
	S2	12
	S4	12

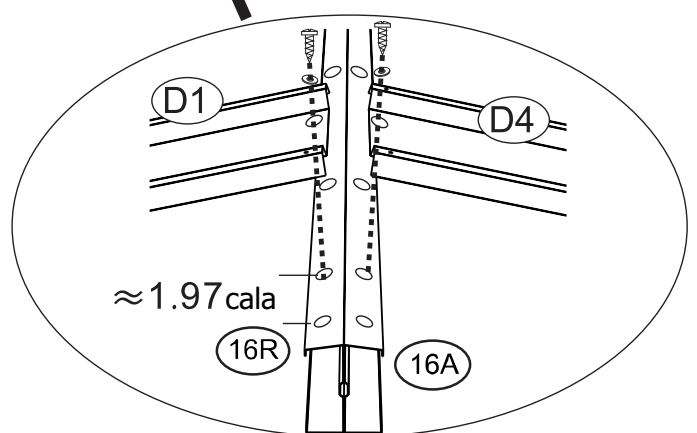
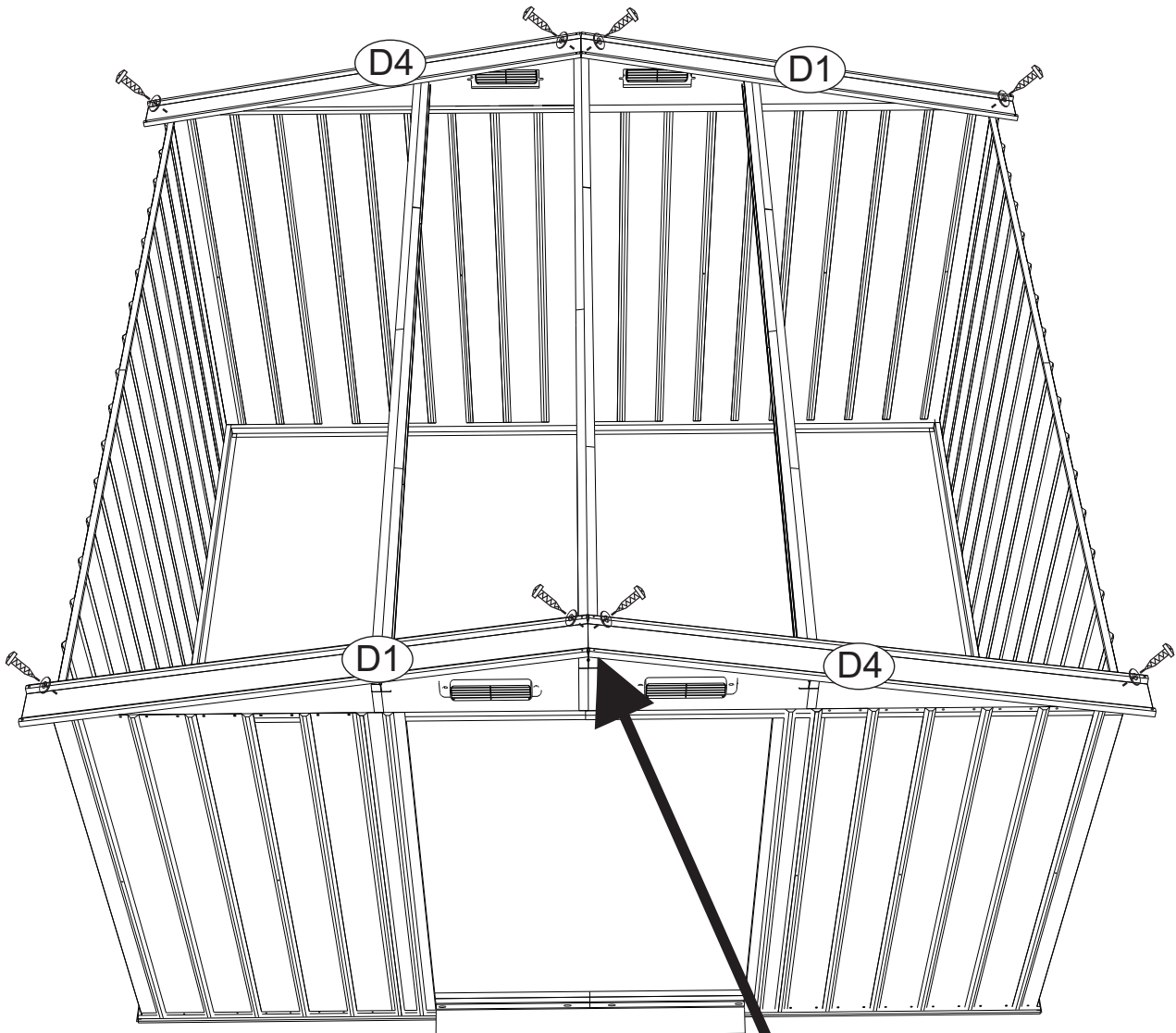

CZĘŚĆ PART	NR NO.	ILOŚĆ QTY
	D1	2
	D4	2
	S1	8
	S3	8

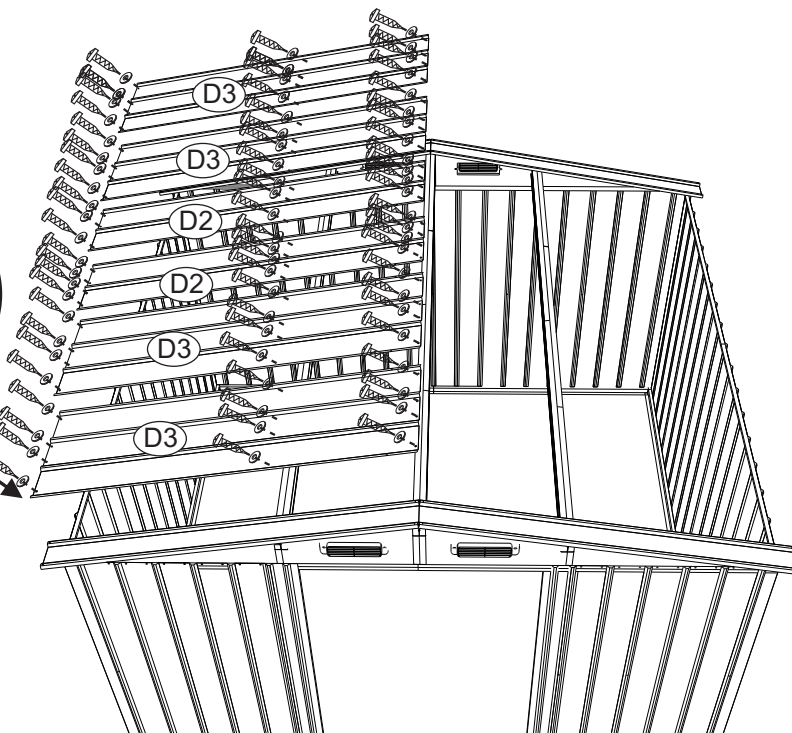
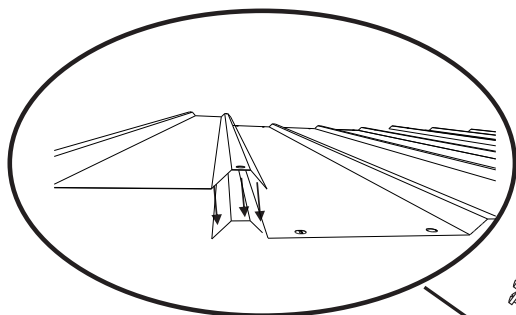



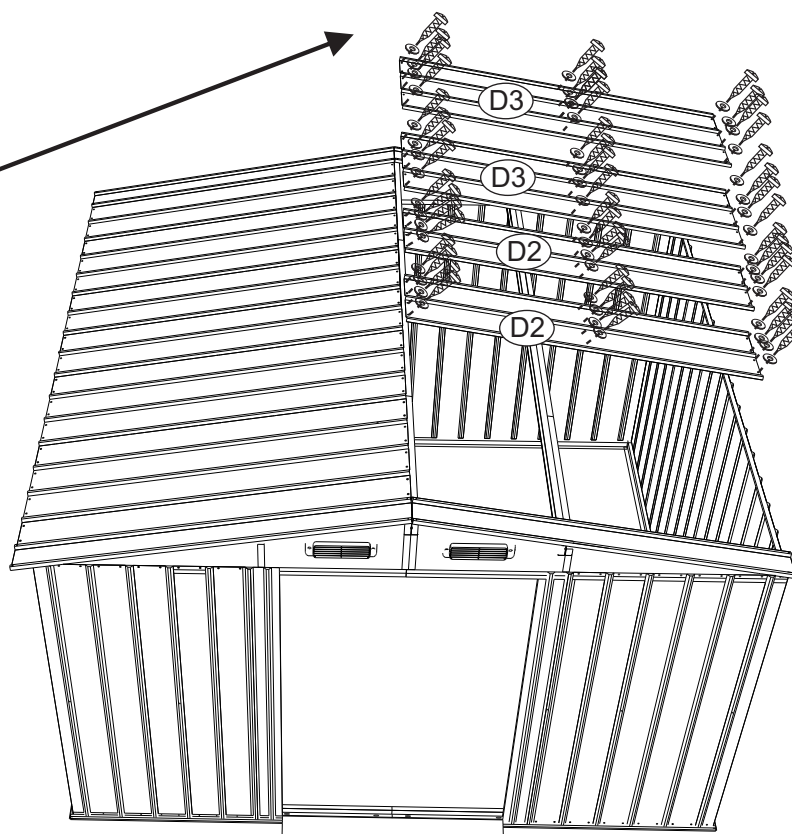
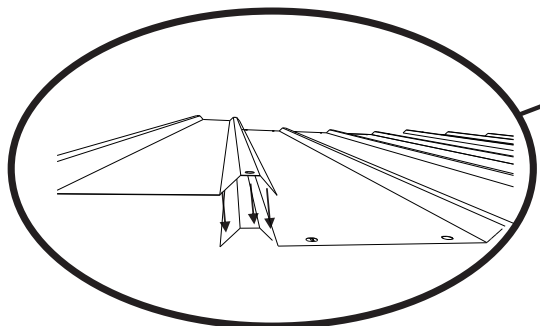

CZĘŚĆ PART	NR NO.	ILOŚĆ QTY
	D2	2
	D3	4
	S1	72
	S3	72

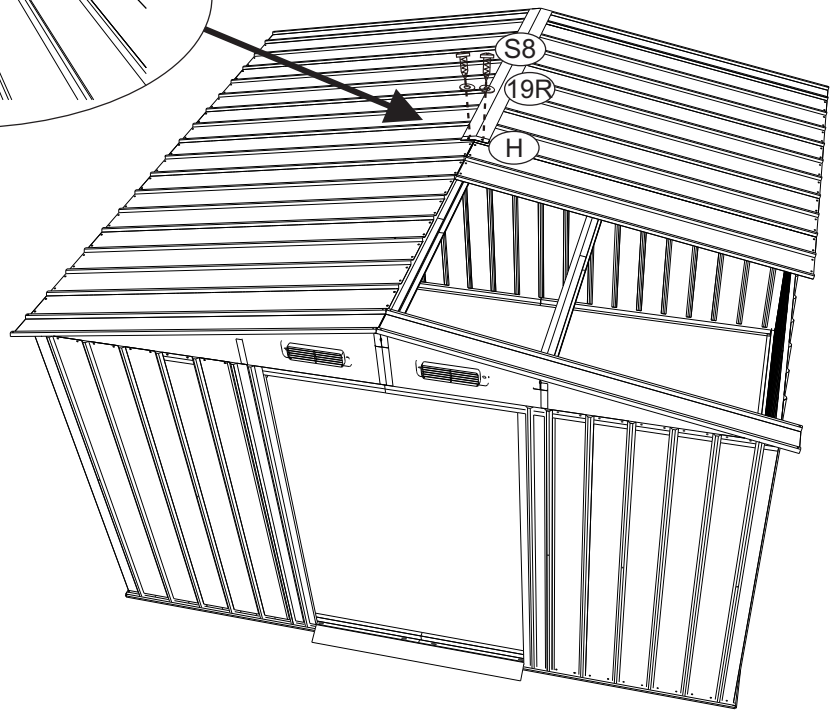
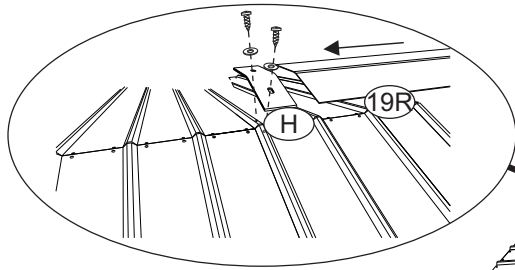



CZĘŚĆ PART	NR NO.	ILOŚĆ QTY
	D2	2
	D3	2
	S1	48
	S3	48

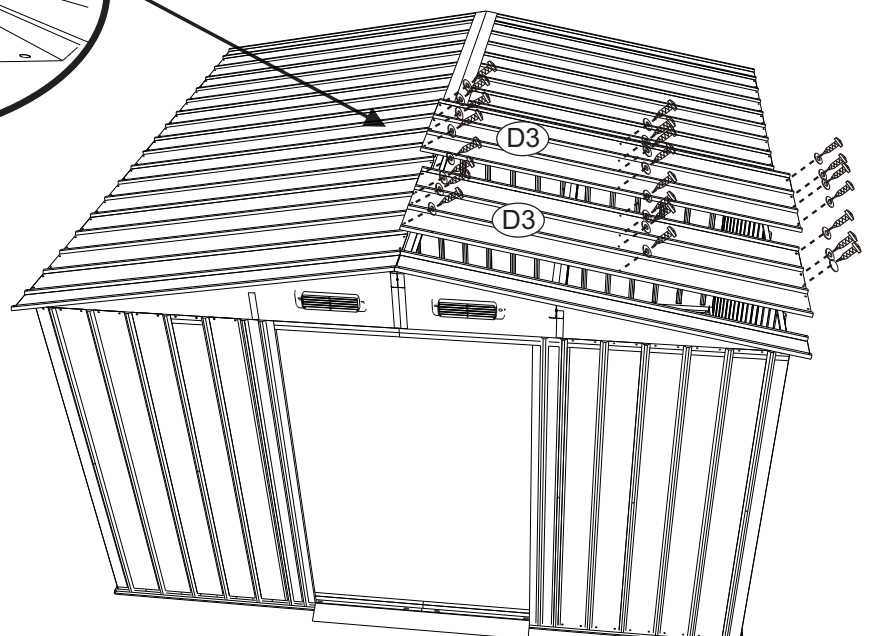
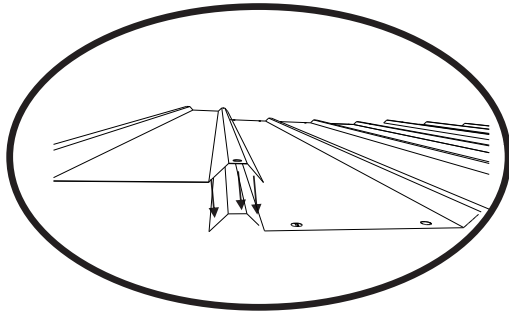

CZEŚĆ PART	NR NO.	ILOŚĆ QTY
	19R	1
	H	1
	S8	2
	S3	2



CZEŚĆ PART	NR NO.	ILOŚĆ QTY
	D3	2
	S1	24
	S3	24

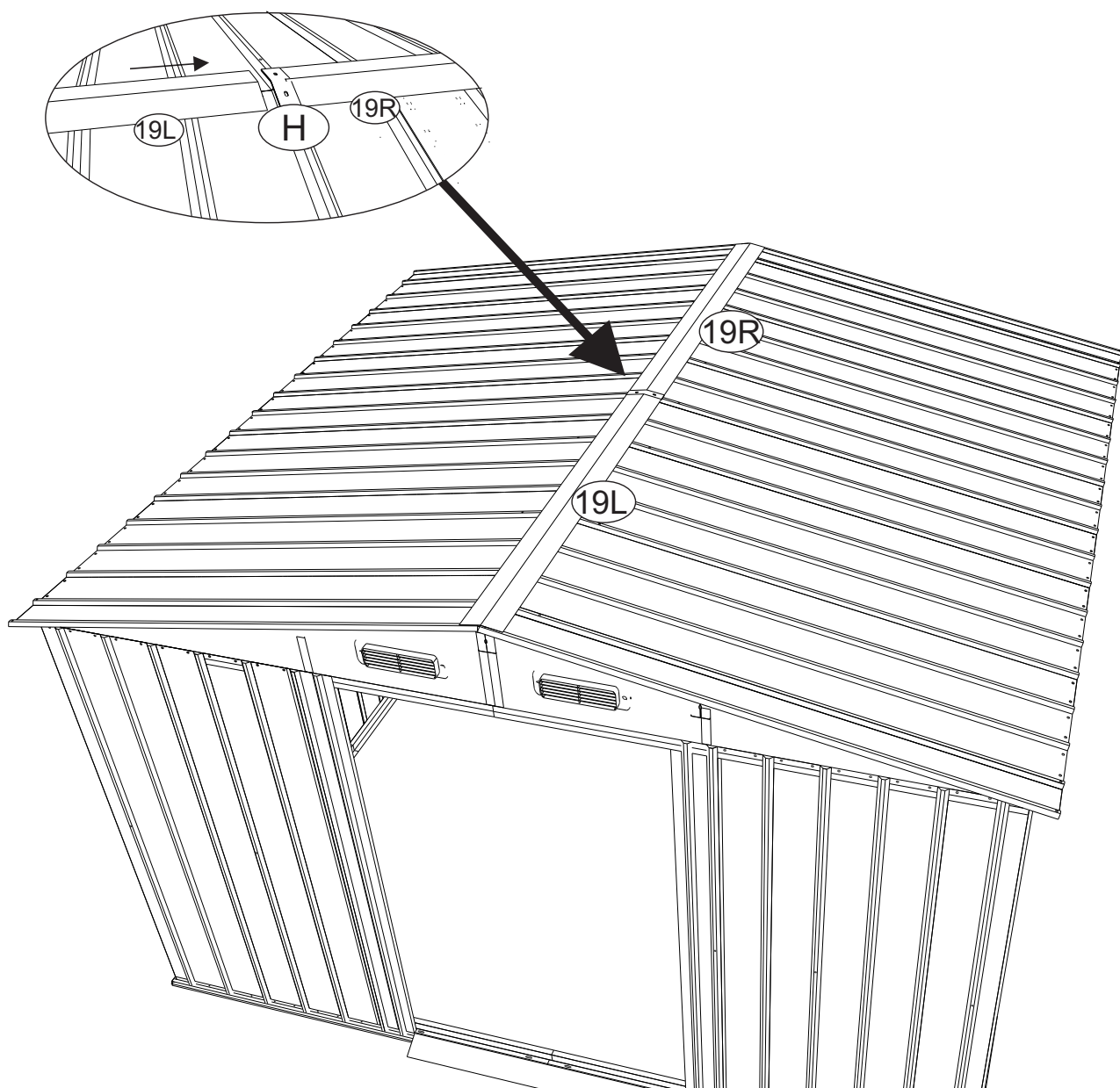

CZĘŚĆ PART	NR NO.	ILOŚĆ QTY
	19L	1

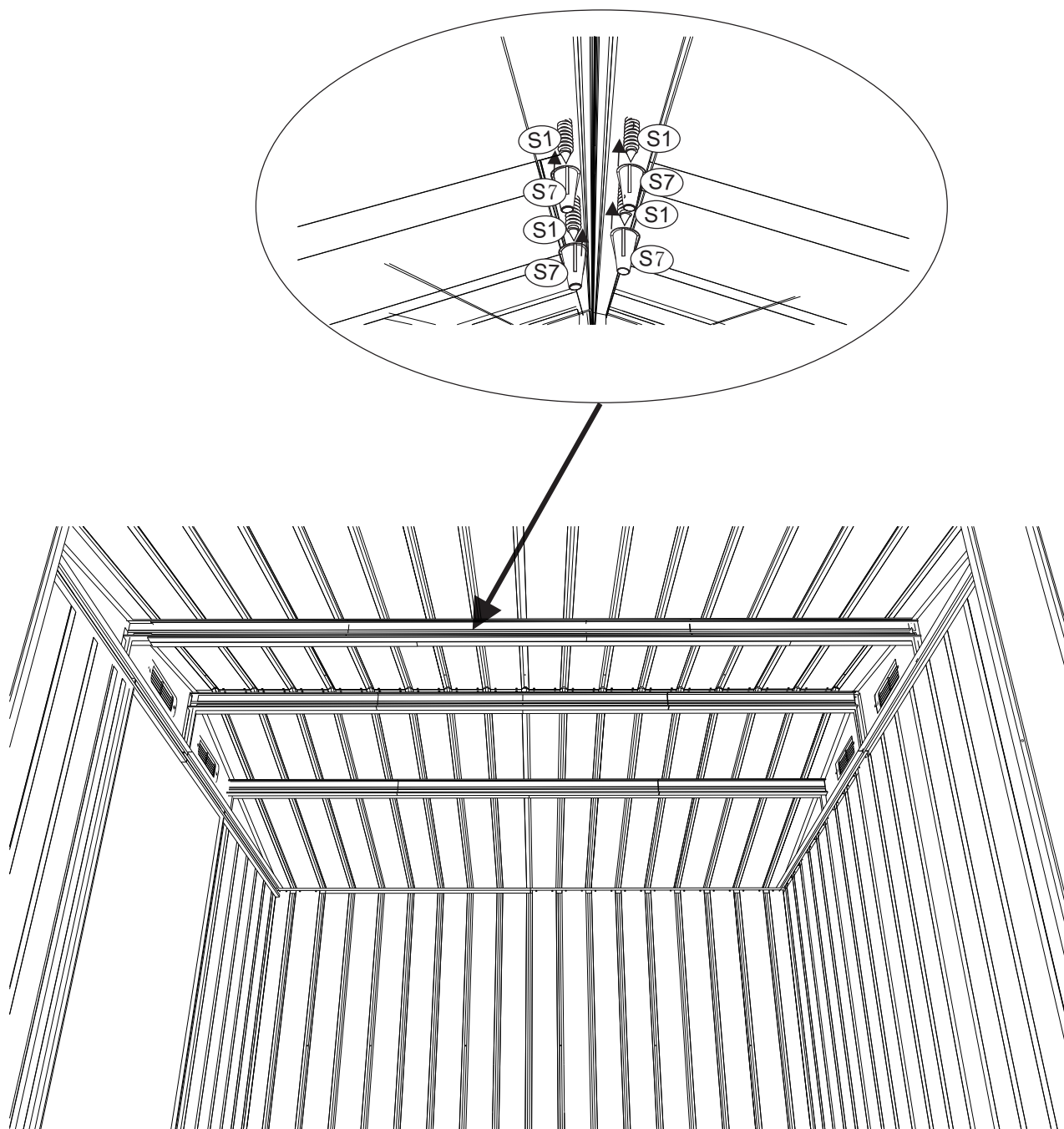



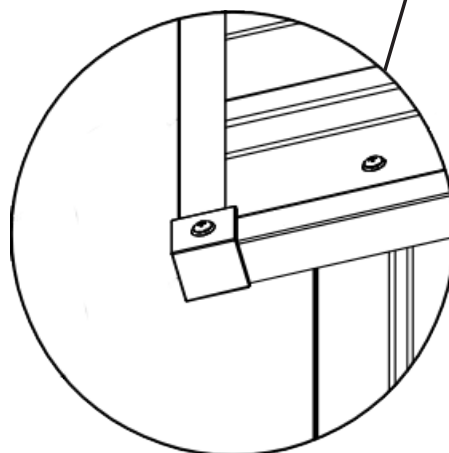
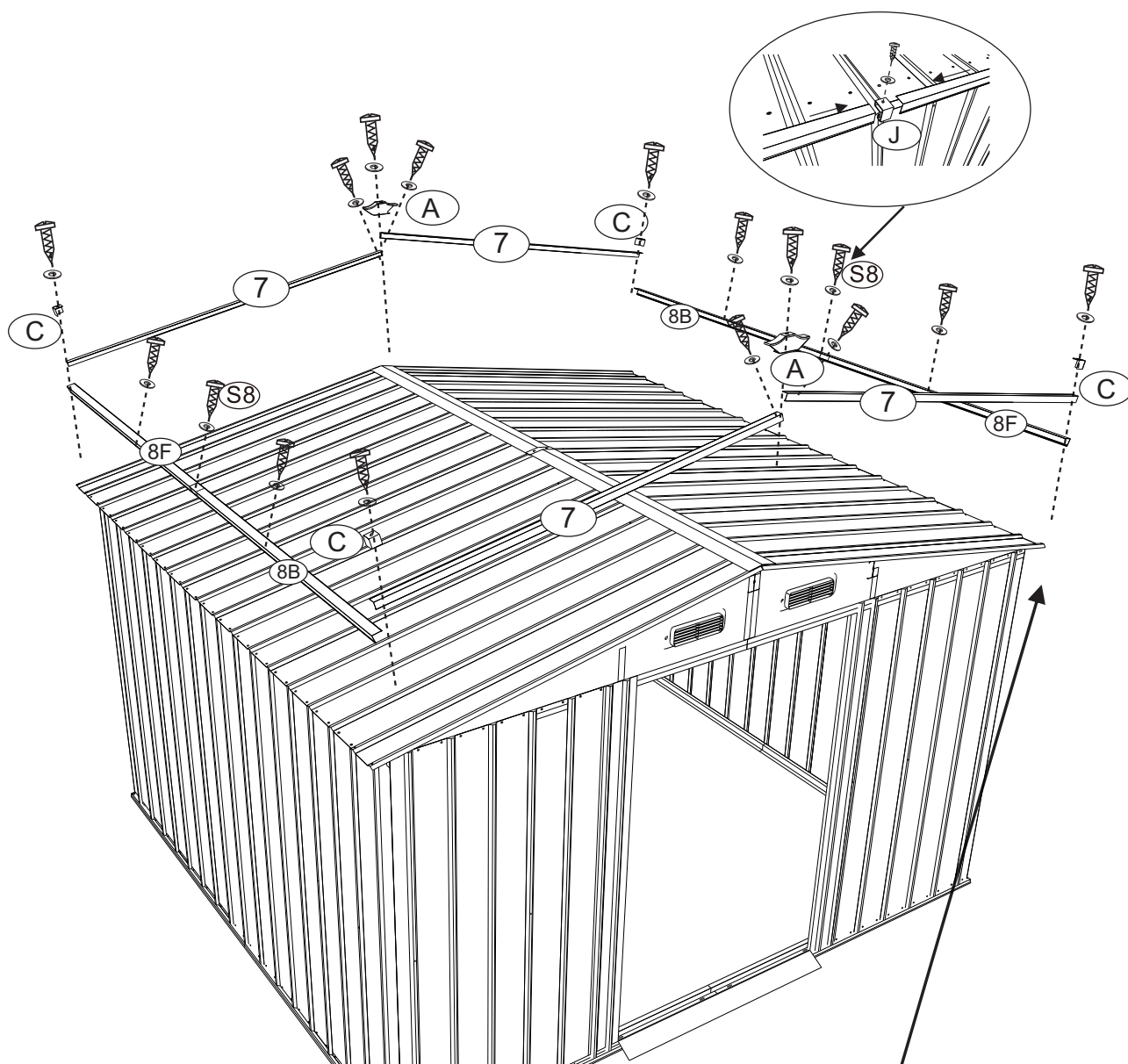

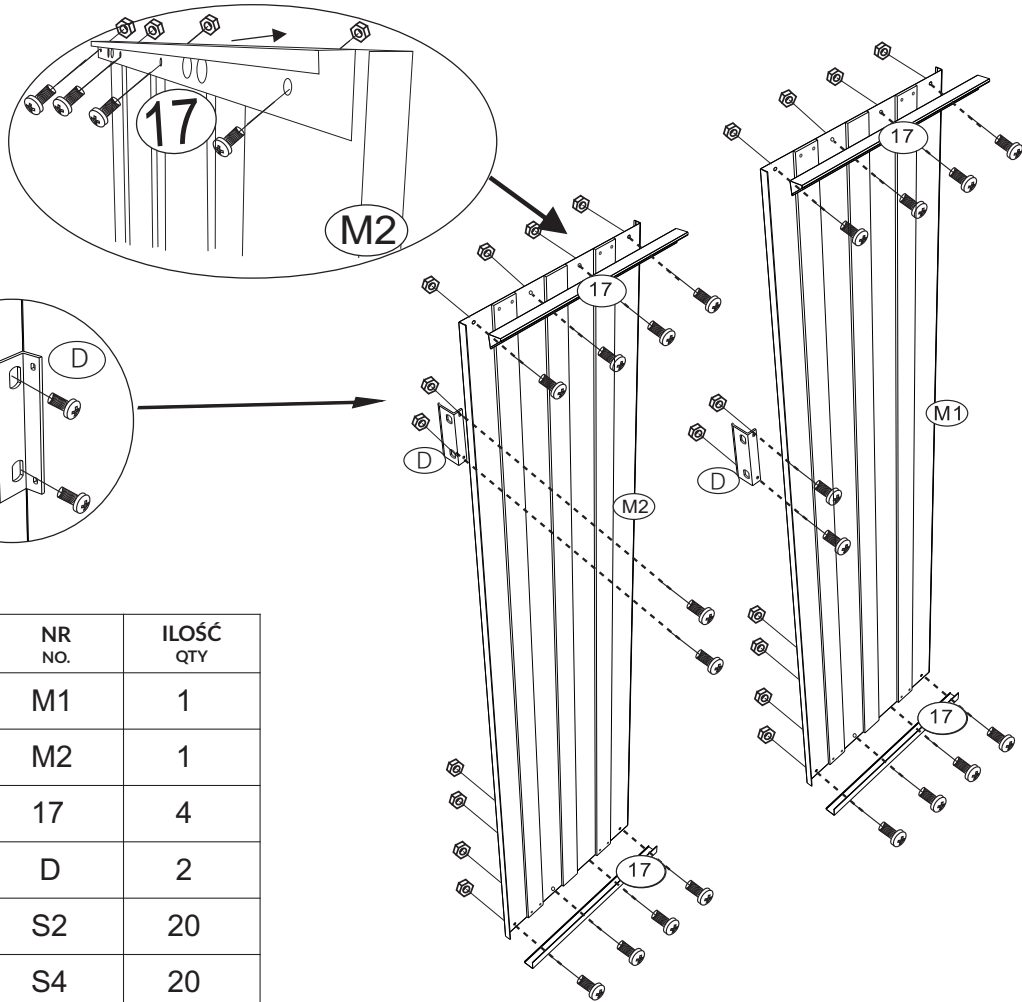

CZĘŚĆ PART	NR NO.	ILOŚĆ QTY
	S7	100

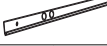

CZĘŚĆ PART	NR NO.	ILOŚĆ QTY
	8F	2
	8B	2
	7	4
	A	2
	C	4
	J	2
	S1	14
	S8	2
	S3	16



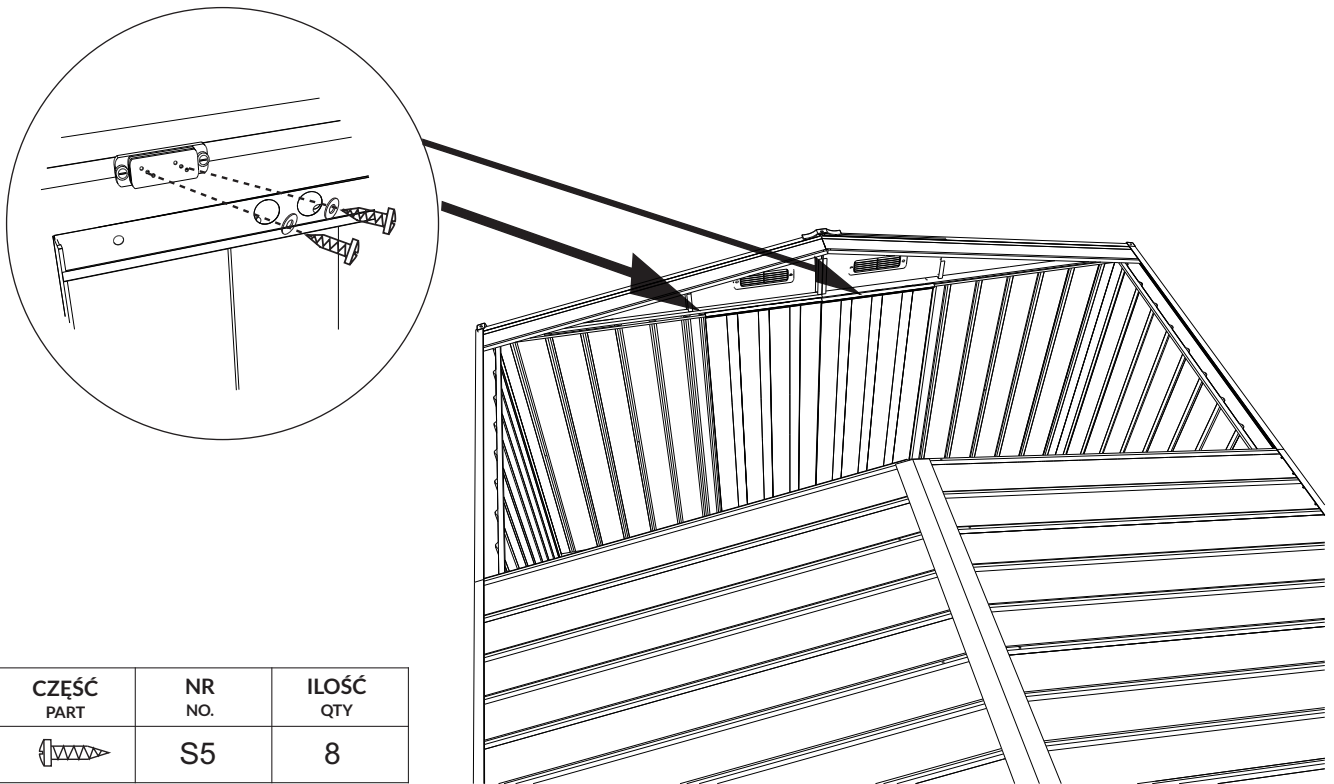

CZĘŚĆ PART	NR NO.	IŁOŚĆ QTY
	M1	1
	M2	1
	17	4
	D	2
	S2	20
	S4	20



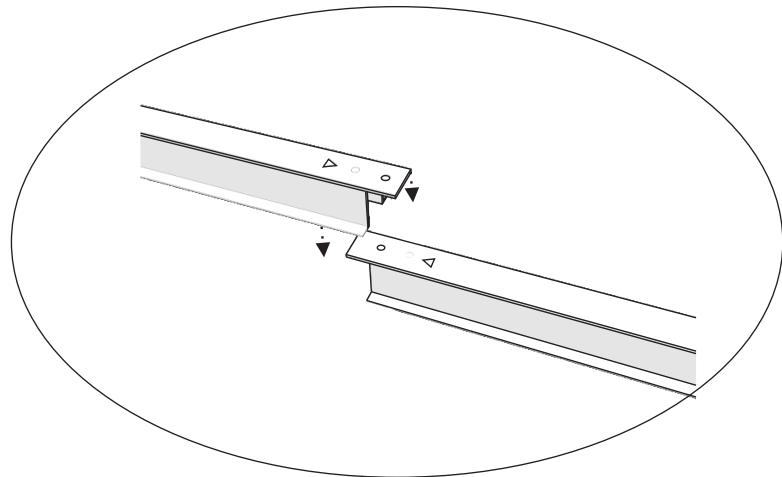
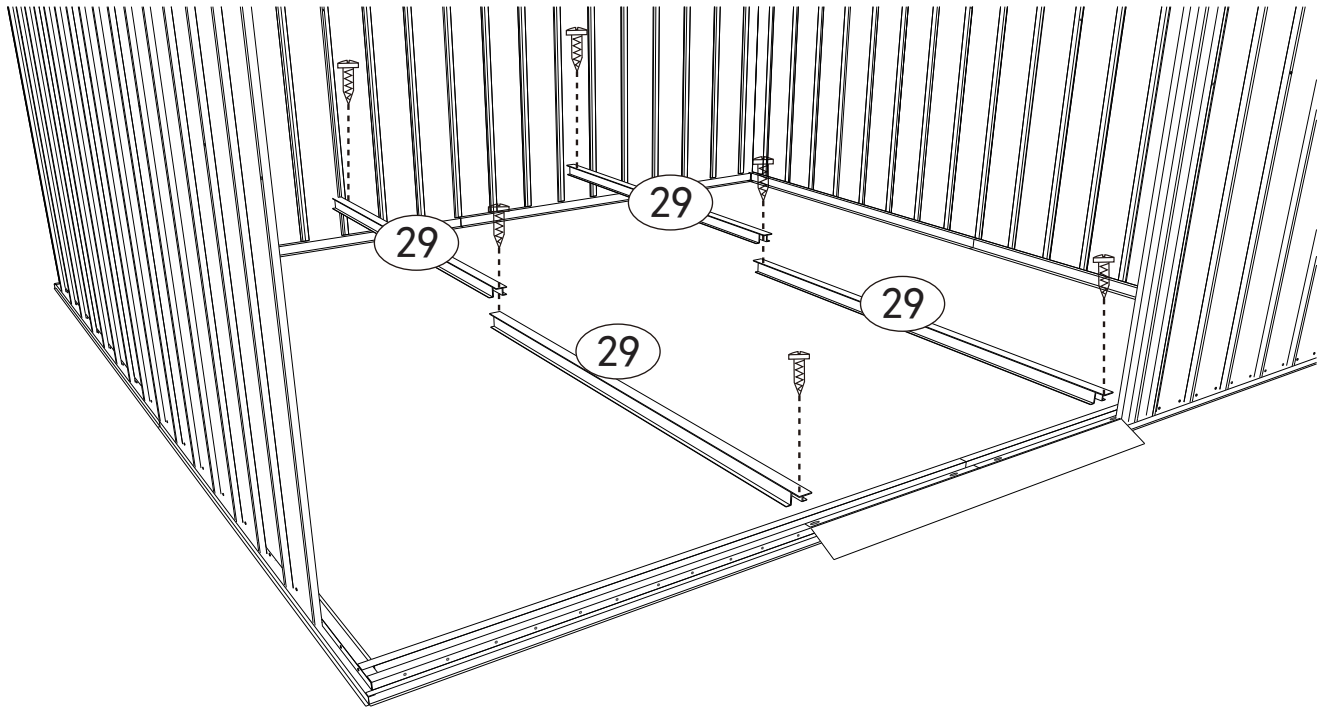

CZĘŚĆ PART	NR NO.	IŁOŚĆ QTY
	S5	8

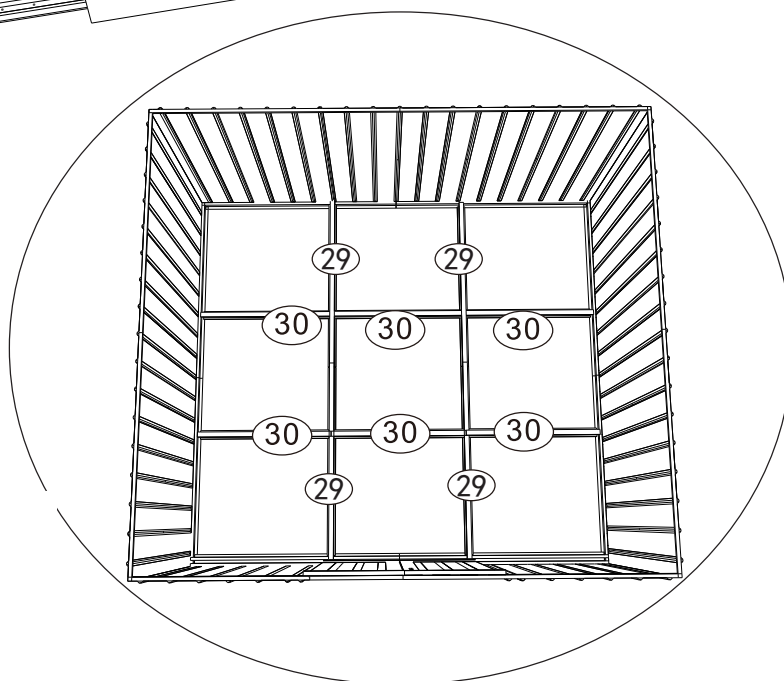
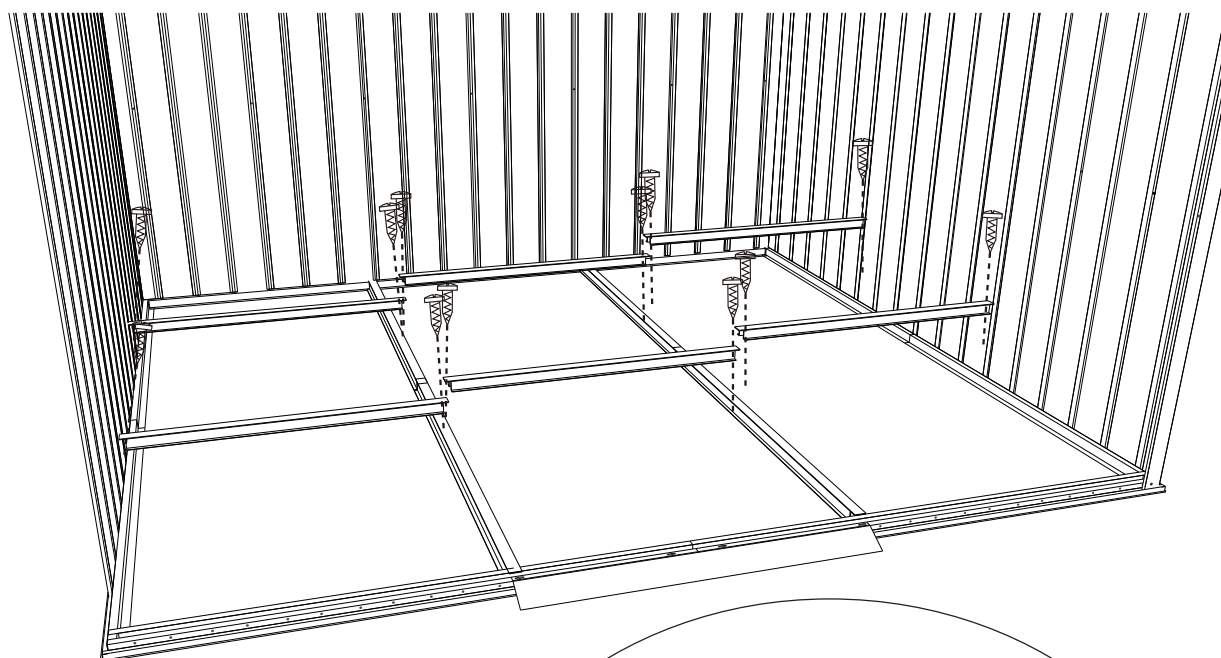

CZĘŚĆ PART	NR NO.	ILOŚĆ QTY
	29	4
	S1	6



CZĘŚĆ PART	NR NO.	ILOŚĆ QTY
	30	6
	S1	12